

Important

This equipment generates, uses and can radiate radio frequency energy. If not installed and used in accordance with the instructions in this manual, it may cause interference to radio communications. The equipment has been tested and found to comply with the limits for a Class B computing device pursuant to EN55022 and to Subpart J of Part 15 of FCC Rules. These specifications are designed to provide reasonable protection against interference when operated in a commercial environment.

For CE-countries:

- The Alpha-30 is in conformity with the CE standards. Please note that a ZEBEX CE-Marked power supply unit should be used to conform to these standards.

For USA & Canada:

- To be used with UL listed and CSA certified computers/POS system.

Radio and television interference

Operation of this equipment in a residential area can cause interference to radio or television reception. This can be determined by turning the equipment off and on. The user is encouraged to try to correct the interference by one or more of the following measures:

- ◆ Re-orientate the receiving antenna
- ◆ Relocate the device with respect to the receiver
- ◆ Move the device away from the receiver
- ◆ Plug the device into a different outlet so that the device and the receiver are on different branch circuits

If necessary, the user should consult the manufacturer, an authorized ZEBEX dealer or experienced radio/television technician for additional suggestion. The user may find the following booklet prepared by the Federal Communications Commission helpful:

“How to Identify and Resolve Radio-TV Interference Problems”.

This booklet is available from the U.S. Government Printing Office, Washington, DC 20402, Stock No. 004000003454.

USER'S MANUAL

ALPHA-30 SERIES

OMNI-DIRECTIONAL LASER SCANNER

HEADQUARTERS
ZEBEX INDUSTRIES INC.
Mobile Computer Division
2F, 531-1, Chung-Cheng Road,
Hsin-Tien City, Taipei, Taiwan, R.O.C.
Tel. +886-2-2218-2018
Fax. +886-2-2218-8670
Web site:www.zebex.com.tw
e-mail:mail@zebex.com.tw

ZEBEX INDUSTRIES INC.
Auto ID Division
3F, 540-1, Chung-Cheng Road,
Hsin-Tien City, Taipei, Taiwan, R.O.C.
Tel. +886-2-2218-3501
Fax. +886-2-2218-1415
Web site:www.zebex.com.tw
E-mail:mail@zebex.com.tw

USA
ZEBEX AMERICA INC.
Ilene Court, Building 11, Unit 4,
Belle Mead, New Jersey 08502, USA
Tel. +1-908-359-2070
Fax. +1-908-359-1272
Web site:www.zebex.com
E-mail:sales@zebex.com

GERMANY
ZEBEX Vertriebs-GmbH
Stimpelwiese 2,
61250 Usingen, Germany
Tel. +49-1805-258443
Fax. +49-1805-258442
Web site:www.zebex.com.tw
E-mail:zbg@zebex.com.tw

IMPORTANT NOTICE

ZEBEX INDUSTRIES INC. MAKES NO WARRANTY OF ANY KIND WITH REGARD TO THIS MATERIAL, INCLUDING, BUT NOT LIMITED TO, THE IMPLIED WARRANTIES OF MERCHANTABILITY AND FITNESS FOR A PARTICULAR PURPOSE. ZEBEX INDUSTRIES INC. SHALL NOT BE LIABLE FOR ERRORS CONTAINED HEREIN OR FOR INCIDENTAL CONSEQUENTIAL DAMAGES IN CONNECTION WITH THE FURNISHING, PERFORMANCE, OR USE OF THESE MATERIALS.

Copyright 1997 by

ZEBEX INDUSTRIES INC.

All other registered trade marks are registered companies' property. ZEBEX is a registered trade mark of ZEBEX INDUSTRIES INC.

All rights reserved, reproduction of this document or any portion of its contents is not allowed without the specific written consent of **ZEBEX INDUSTRIES INC.**

Printed In January, 1997

TABLE OF CONTENTS

PREFACE.....	iii
CHAPTER 1 THE ALPHA-30.....	1
1.1 Unpacking The Alpha-30.....	2
1.2 Scanning Bar Codes With The Alpha-30.....	3
1.3 Scanner Labeling.....	5
1.4 Maintaining The Scanner.....	7
1.5 Controlling The Scanner From The POS System.....	7
CHAPTER 2 INSTALLING THE ALPHA-30.....	9
2.1 Installing The Scanner On a Counter Surface.....	10
2.2 Installing The Scanner Using The US-30 Universal Stand.....	13
APPENDIX 1 CONNECTOR TYPES AND PIN OUT CONFIGURATION.....	17
A.1. Pinout Configuration For The Data Port Of the Scanner.....	18
A.2. Connector Types And Pin-Out Configuration For Us-30 Universal Stand And P/N 53110 Internal Cable Adaptor.....	20
APPENDIX 2 TECHNICAL SPECIFICATION.....	22
APPENDIX 3 TROUBLE SHOOTING.....	25
C.1. Trouble Shooting.....	26

PREFACE

ALPHA-30 is a high performance omni-directional presentation laser scanner. Bar code labels are read by presenting the labels to the scanner. Scanning labels with ALPHA-30 hardly requires any arm movement. As a result only little free space on the counter top is required.

ALPHA-30 can be fixed either on a counter surface or on a US-30 universal stand. The US-30 universal stand allows you to direct the scan pattern in a way that is optimal for your application by adjusting the scanner window forward, backward, right or left.

ALPHA-30 reads most all popular bar-code symbologies. An outstanding feature of ALPHA-30 is its programmable sleep mode. If the scanner is not used within a programmable period of time, the scanner turns off automatically. The scanner can be waked up by pressing the switch on the top of the scanner or on the US-30 stand.

ALPHA-30 is available in two versions. Each version features a specific dual interface combination for communication with the POS system. The dual interface combinations are: RS-232C/OCIA and IBM RS-485/Keyboard Wedge.

This manual contains two chapters and three appendices. The first chapter describes ALPHA-30 and its general features. ALPHA-30 can be installed on a counter surface or a US-30 universal stand. Instructions for both installations are described in the second chapter. The default settings can be changed with the bar-code labels from the Configuration Guide that comes with the scanner. Appendix A gives the pin out configuration for the Data ports of the scanner. The pin out configuration is necessary if you want to make a new cable for communication with the POS/computer. Appendix B gives an overview about the technical specifications of 0. Go to Appendix C for troubleshooting if the scanner is not working properly.

CHAPTER 1

THE ALPHA-30

1.1 UNPACKING ALPHA-30

Take out the scanner and its accessories from the box and packing material. Make sure you have received all of the items ordered by referring to the packing list. Check if the scanner and accessories are received in good condition. Refer to the upper figure 1.4 on page 5 to locate the label with the interface information and make sure that the interface of the scanner corresponds with the POS systems interface. Immediately contact your dealer if there is anything missing or appears to be damaged, or if the supported interface does not correspond with the POS system interface.

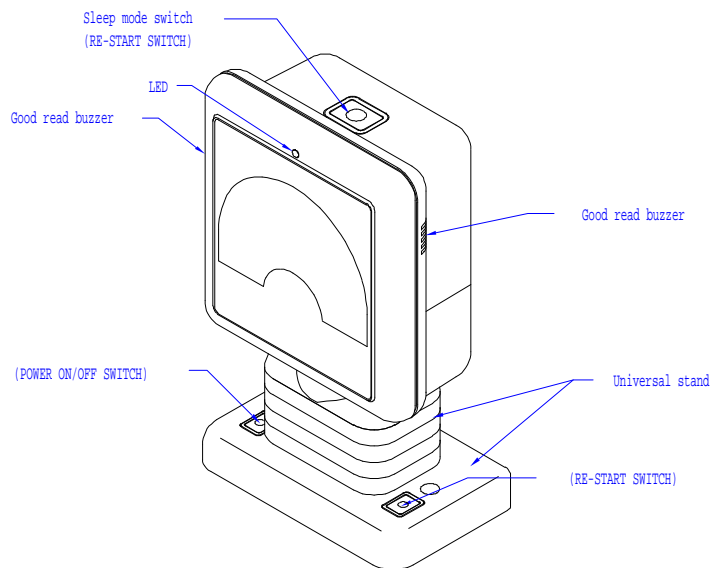

Figure 1.1

The various parts of ALPHA-30 are:

- ON/OFF Switch** - Control the main power of ALPHA-30.
- Sleep Mode Switch** - When ALPHA-30 enters into the sleep mode, the scanner can be waked up by pressing this switch. The sleep mode feature can be programmed using the menu labels from the Programming Guide.

NOTE: The default value for the sleep mode time-out is set to 30 minutes. When the scanner is in sleep mode, the LED is intermittently flashing red.

- LED** - A red LED indicates the scanner is ready to read a bar code while a green LED indicates a good read.

- Good Read Buzzer** - If the data is captured correctly, the buzzer will be heard. Both the volume and frequency are programmable using the menu labels from the Programming Guide.

- Universal stand (US-30)** - This stand allows you to direct the scan pattern in a way that is the best for your application by adjusting the scanner window forward, backward, right or left.

1.2 SCANNING BAR CODES WITH ALPHA-30

ALPHA-30 omni-directional laser scanner features a 7 directions scan field with a 24 lines scan pattern. Bar code labels can be read easily by presenting them to the scanner.

The scanner's scan volume is illustrated in figure 1.2 on the next page. The density of the pattern has an optimum at 70 mm (3 inches) from the scanner window, but bar codes can be read up to 250 mm (10 inches) from the scanner window.

The scanner window can be adjusted forward, backward and left or right which allows you to direct the optimal reading zone in a way that suits your application most.

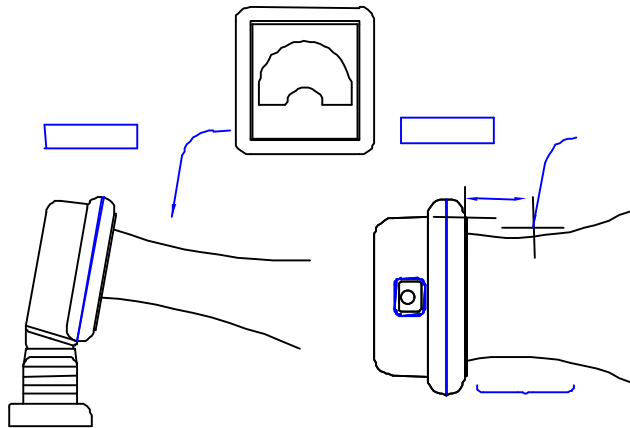

Figure 1.2

How to scan a bar code label with ALPHA-30 is very simple: simply by presenting the label of the product to the scanner as illustrated here in figure 1.3.

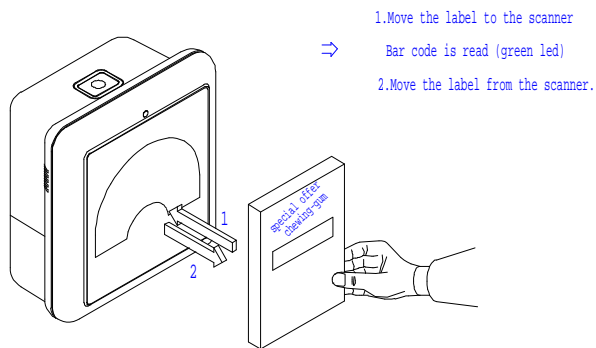

Figure 1.3

Important:

- Please prevent from touching the scan window with the articles to be scanned. This might cause tinny scratches which consequently can have a negative influence on the scanning performance.

1.3 SCANNER LABELLING

There are two labels on the housing of ALPHA-30 as illustrated in figure 1.4 (for IBM validated scanner these two labels are also present at the exterior of the scanner). In addition, there are two labels visible through the scanner window. All the labels are attached by the manufacturer and should not be removed.

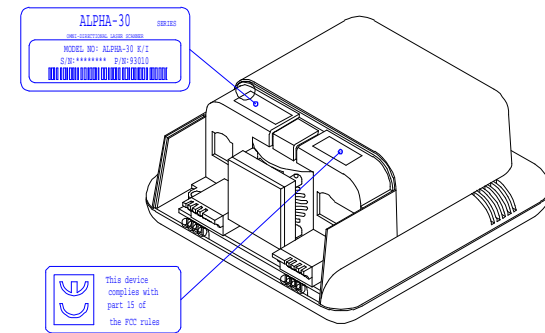

Figure 1.4

You will find a serial number on the scanner. This number is underneath the bar code label as illustrated in figure 1.4. This official registration number is strictly related to the device. The dealer can ask for this number when the scanner needs servicing.

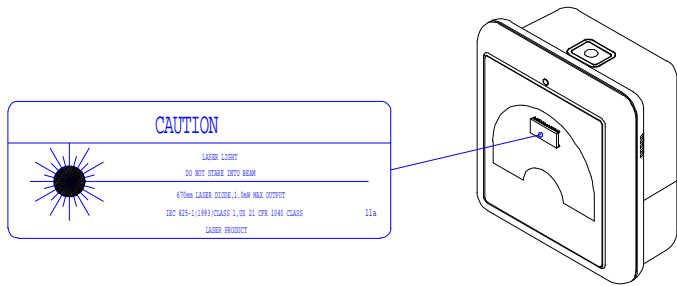

Figure 1.5

Laser Safety

ALPHA-30 laser scanner complies with safety standard IEC 825-1 (1993) for a Class I laser product. It also complies with U.S. 21CFR1040 as applicable to a Class IIa laser product. Avoid long term viewing of direct laser light.

Optical: The use of optical instruments with this product will increase eye hazard. Optical instruments include binoculars, microscopes and magnifying glasses but do not include eye glasses worn by the user.

Radiant Energy: ALPHA-30 uses a low-power laser diode operating at 670nm in an opto-mechanical scanner resulting less than 0.6 mW peak output power. Laser light observed at 13cm (5.1 inches) above the window through a 7 mm (0.28 inches) aperture and averaged over 1000 seconds is less than 3.9 μ W PER CDRH Class IIa specification. Do not attempt to remove the protective housing of the scanner, as unscanned laser light with a peak output up to 0.8mW would be accessible inside.

Laser Light Viewer: The scanner window is the only aperture through which laser light may be observed on this product. A failure of the scanner motor, while the laser diode continues to emit a laser beam, may cause emission levels to exceed those for safe operation. The scanner has safeguards to prevent this occurrence. If, however, a stationary laser beam is emitted, the failing scanner should be disconnected from its power source immediately.

Adjustments: Do not attempt any adjustments or alteration of this product. Do not remove the protective housing of the scanner. There are no user-serviceable parts inside.

CAUTION: Use of controls or adjustments or performance of procedures other than those specified herein may result in hazardous laser light exposure.

1.4 MAINTAINING THE SCANNER

ALPHA-30 laser scanner rarely needs any maintenance. Only an occasional cleaning of the scanner window is necessary in order to remove dirt and fingerprints. The cleaning of the scanner window can be done during operation with a soft lint-free cloth and a non-abrasive glass spray cleaner.

1.5 CONTROLLING THE SCANNER FROM THE POS SYSTEM

ALPHA-30 can be controlled from the POS system via the RS-232C interface. Controlling can be accomplished by transmitting the following single byte commands to the scanner. The default setting of the commands are as follows (more details are available upon request):

ASCII Code	Function	Byte is Also Called:
OE Hex	enable (resumes disable)	Shift Out or <Ctrl-N>
OF Hex	disable	Shift In or <Ctrl-O>
05 Hex	power-up re-initialization	ENQ or <Ctrl-E>
12 Hex	sleep	DC2 <Ctrl-R>
14 Hex	wake up (resumes sleep)	DC4 <Ctrl-T>

When the scanner is disabled, the motor of the scanner will stay on until the scanner goes into sleep mode.

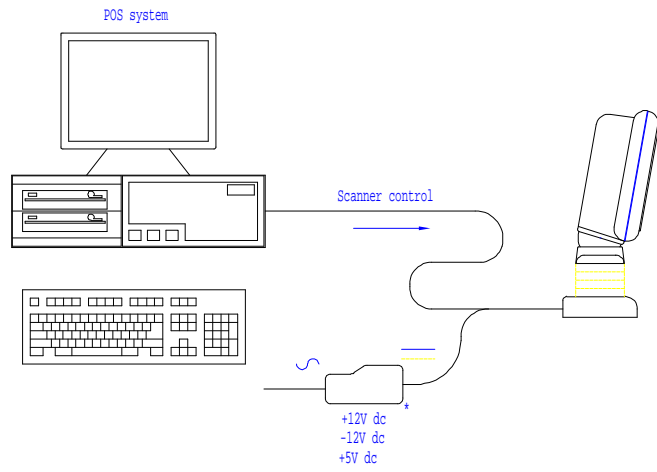

Figure 1.6

CHAPTER 2

INSTALLING THE ALPHA-30

There are two different ways to install ALPHA-30 depending on how you want to use it: fix it on a counter surface or on a US-30 universal stand.

To install on a counter surface, please refer to Section 2.1.

To install on the US-30 universal stand, please refer to Section 2.2.

As there are many computer devices on the market, ZEBEX provides a large number of communication cables as options. Make sure you order the right cable to connect the scanner to your POS or computer.

Notice:

- ***It is our advice to turn off your POS system before starting the installation of the scanner. By following this precaution, you can avoid your computer from electronically being damaged.***
- ***It is also our advice to install the scanner in an air circulated place out of the direct sunlight.***

2.1. INSTALLING THE SCANNER ON A COUNTER SURFACE

You are advised to mount the scanner in a fixed counter surface position by following the procedure here below.

1. Locate the small hole at the back cover of the scanner. Press it with the tip of a stick to remove the back cover of the scanner as illustrated in figure 2.1.

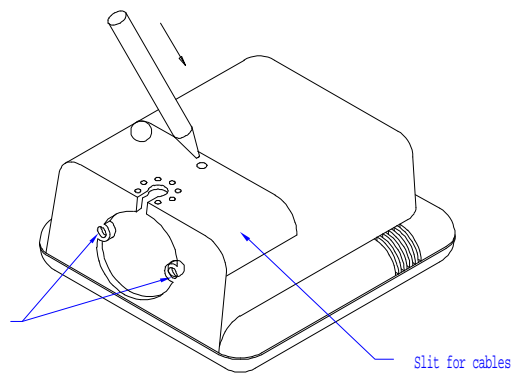

Figure 2.1

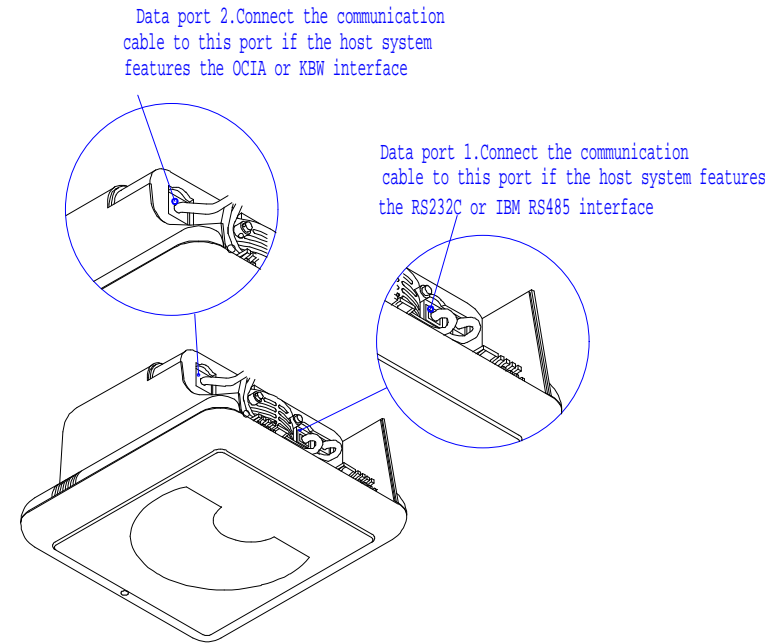

Figure 2.2

2. If the POS system is the RS-232C or IBM 485 interface, plug the communication cable with the 8 pin modular jack into Data port 1, or if the POS system interface is OCIA or Keyboard Wedge, plug the communication cable into Data port 2. Plug the other end of the cable into the appropriate serial port of your POS or computer. Use the ZEBEX universal power supply. Lead the cables through the scanner as illustrated in figure 2.2.

Important:

- ***If the POS system is an IBM 4683/4684 POS, the scanner with IBM RS-485 interface should only be connected to port 17 of the POS.***
 - ***If the POS system is an IBM 4693/4694 POS, the scanner with IBM RS-485 interface should only be connected to port 9E of the POS.***
3. Use the back cover as a template to mark the places for the mounting holes at the counter surface and bore two holes.

- Lead the communication cable and power supply cable through the slit. Then use the two screws to fasten the back cover to the surface as illustrated here follows:

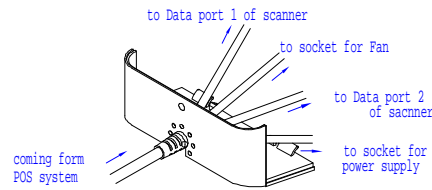

Figure 2.3

- Place the scanner as illustrated in figure 2.4 and rotate the scanner around the cover. Make sure the connectors and cables are placed properly as illustrated in the figures to allow easy attachment of the scanner to the back cover. Press the scanner until a “click” is heard.
- Turn on the POS system.

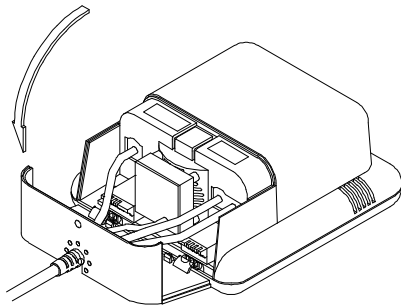

Figure 2.4

You may start scanning bar-codes as soon as the scanner is installed. If you want to change the default setting of the scanner, go to the “Programming Guide” that is included with the scanner.

2.2. INSTALLING THE SCANNER USING THE US-30 UNIVERSAL STAND

To install the scanner on a US-30 universal stand, the cables should be led through the central hold of the US-30 universal stand to be connected to the scanner. The stand should be mounted to the counter top first and then the scanner to the stand.

Notice:

- We strongly suggest you to use two screws to mount the scanner on the counter surface.**

Follow the next few steps to mount the stand on a counter:

- If you prefer to mount the stand with two screws, on the counter top where the scanner is to be installed, mark the two places for the mounting holes. Refer to the figure for the relative position and the diameter. Do not mount the stand to the counter top yet.

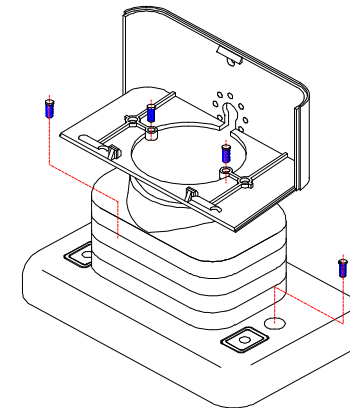

Figure 2.5

- Lead the communication cable with the 8 pin modular jack and the power supply cable from the bottom through the stand. Refer to figure 2.6 to locate the hole through which the cable should be led.
- Press the small hole at the back cover of the scanner with the tip of a stick to remove the back cover, as illustrated in figure 2.1.
- Plug the communication cable with the 8 pin modular jack in the appropriate Data port of the scanner. Refer to figure 2.2 for the Data port applicable to the interface used. Plug the other end of the cable into the appropriate serial communication port of the POS system.

Important:

- **If the POS system is an IBM 4683/4684 POS, the scanner with IBM RS-485 interface should only be connected to port 17 of the POS.**
- **If the POS system is an IBM 4693/4694 POS, the scanner with IBM RS-485 interface should only be connected to port 9E of the POS.**

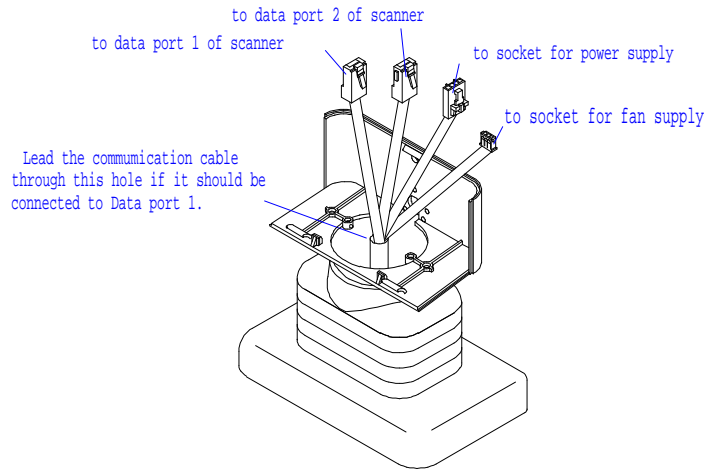

Figure 2.6

5. Use either screws or the double sided tape to fasten the stand at the bottom of the plate.

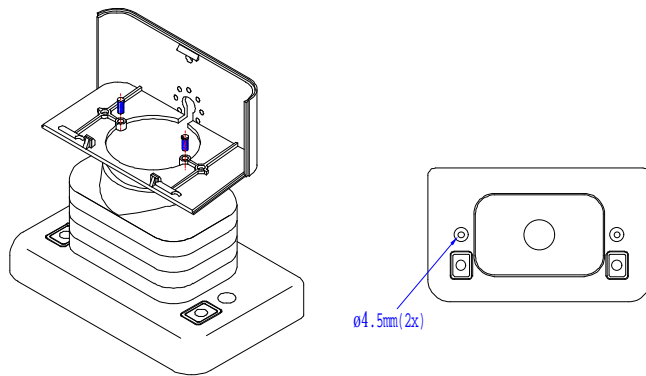

Figure 2.7

6. Place the scanner onto the US-30 universal stand and rotate the scanner as shown in figure 2.8. Make sure that the connectors and cables are placed as indicated in the figures, such to allow easy attachment of the scanner to the back cover. Press the scanner until a “click” is heard.

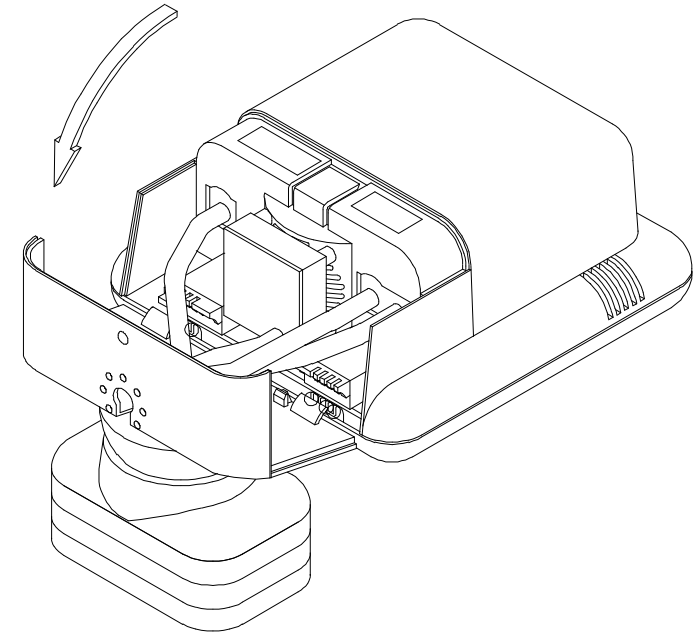

Figure 2.8

7. Switch on the POS system.

You may start scanning bar-codes as soon as the scanner is installed. If you want to change the default setting of the scanner, go to the “Programming Guide” that is included with the scanner.

This page is intentionally left blank.

APPENDIX A

CONNECTOR TYPES AND PIN OUT CONFIGURATION

A.1. PINOUT CONFIGURATION FOR THE DATA PORT OF THE SCANNER

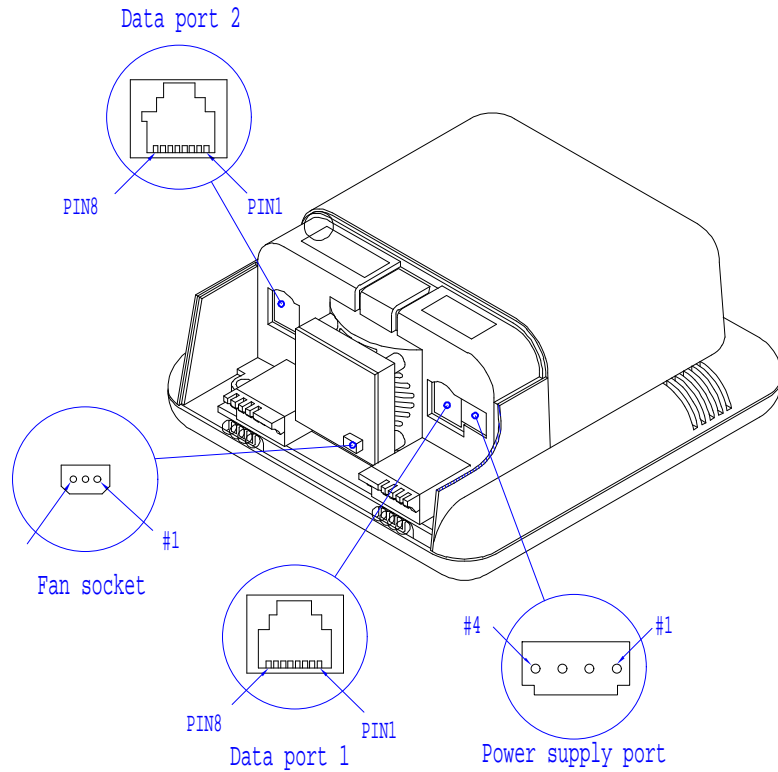

Figure A.1

Pin Definition For Dual Interface Version RS-232C/OCIA

RS-232C Interface Data Port 1		
Pin	Description	Direction
1	CTS	input
2	RD	input
3	TX	output
4	RTS	output
5	GND	-
6	N.C.	-
7	for factory use only	
8		

OCIA Interface Data Port 2		
Pin	Description	Direction
1	lfid	input
2	DATA	output
3	DATA RTN	output
4	CLOCK IN	input
5	GND	-
6	CLOCK IN RTN	input
7	RESET	input
8	RESET RTN	input

Pin Definition For Dual Interface Version IBM RS-485/KB Wedge

IBM RS485 Interface Data Port 1		
Pin	Description	Direction
1	N.C.	-
2	IO-A	input/output
3	IO-B	input/output
4	N.C.	-
5	GND	-
6	N.C.	-
7	for factory use only	
8		

KB Wedge Interface Data Port 2		
Pin	Description	Direction
1	lfid1	input
2	KB_DATA	output
3	KB_CLK	input
4	PC_DATA	input
5	PC_GND	input
6	PC_CLK	input
7	PC_5V	input
8	lfid2	input

Pin Definition For Power Supply Port and Fan Port

Power Supply port	
Pin	Description
1	+5V
2	-12V
3	+12V
4	GND

Fan port	
Pin	Description
1	+5V
2	RE-START
3	GND

A.2. CONNECTOR TYPES AND PIN-OUT CONFIGURATION FOR US-30 UNIVERSAL STAND AND P/N 53110 INTERNAL CABLE ADAPTOR

US-30, the universal stand, and the P/N 53110 Internal cable adaptor are good for ALPHA-30. The pin-out of the D-Sub 25pin communication port varies according to the interface versions of the US-30. Please refer to p 21 for detailed information. Besides, US-30 supports an auxiliary RS-232C port. When it works with the Alpha-30R/A version, it can be connected with an external RS-232C hand-held scanner (of any type).

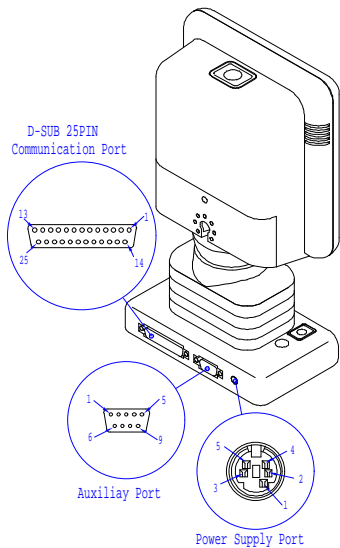

Figure A.2

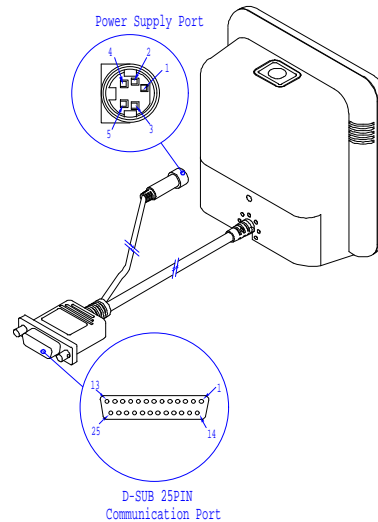

Figure A.3

D-Sub 25 Pin Communication Port

RS-232/OCIA Interface		IBM 468x/469x KB Wedge Interface		
Pin	Description	Description		
1	Shield GND	Shield GND		
2	TX	RS-232 C Interface	I0-A (input/output)	
3	RX		I0-B (input/output)	
4	RTS		N.C.	
5	CTS		N.C.	
7	GND	GND		
11/18	for factory use only	for factory use only		
12	CLOCK IN RTN	OCI A Interface	PC CLOCK	
13	DATA RTN		KB CLOCK	
14	CLOCK IN		PC DATA	
15	DATA		KB DATA	
24	RESET		PC 5V output	
9	lfid1		lfid1	
10	RESET RTN	lfid2	Key board Wedge Interface	
6, 8, 16, 17, 19, 20, 21, 22, 23, 25		N.C.		

Power Supply Port

Pin	Description
1	GND
2	+5V
3	+12V
4	-12V
5	GND
Shell	Shield

Auxiliary Port (for US-30 only)

Pin	Description
1	N.C.
2	RX
3	TX
4	N.C.
5	GND
6	N.C.
7	N.C.
8	N.C.
9	+5V DC output

APPENDIX B

TECHNICAL SPECIFICATION

SPECIFICATIONS

ELECTRICAL

Supply Voltage	100~240V AC, 50/60 Hz
DC Input To Scanner	+5V DC, 450mA, +12V DC, 150mA -12V DC, 50mA
Interfaces	RS232C Interface Keyboard Emulation (IBM PC/AT, PS/2 compatible) OCIA Interface IBM RS-485 (IBM 4683/4684/4693/4694) Interface

OPTICAL

Light Source	670 ± 5 nm visible laser diode
Depth Of Field	250 mm (10 inches)
Scan Pattern	7 direction scan field, 24 line scan pattern
Scan Rate	2400 scans / second

ENVIRONMENT

Operating Temp.	0 °C ~ 40 °C
Humidity	20% ~ 95% RH (non-condensing dew)

PHYSICAL

Weight	700 g (excl. stand)
Dimensions	L x W x D: 160 x 150 x 75 mm : 6.29 x 5.90 x 2.95 inch

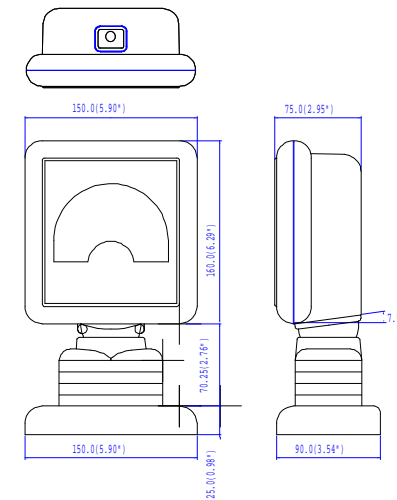

Figure B.1

SPECIFICATIONS

DECODING

Bar Code Types EAN/UPC/JAN + Add-on Code 128, EAN 128,
Code 39, Code 32, Codabar, Interleaved 2 of 5

SAFETY

Laser Safety IEC 825-1 (1993) Class I, U.S. 21CFR1040 Class IIa
Electrical Safety EN 60950 second edition
UL1950, c-UL (according CSA22.2.950)
Flammability Ratio 94V-0

EM COMPATIBILITY

Radio And TV Interference EN 55022 Class B (1994), FCC part 15 Class B
(1992)
Radio Frequency EN 50082-1 (1992)
Immunity
ElectroStatic Discharge (ESD) IEC 801-2 (1991)
Radio Frequency EM-immunity IEC 801-3 (1984) / ENV 50140 (1993)
Electrical Fast Transient IEC 801-4 (1988)

APPENDIX C

TROUBLE-SHOOTING

C.1 Trouble-shooting

This section contains information about how to solve problems that you may encounter when operating the scanner. If troubles occur, please refer to the following diagnostic tips as a mean to solve the trouble. However, before referring to the tips, make sure that the scanner is installed as instructed in Chapter 2 and that all cables are properly connected. If the problem remains, contact your dealer.

Problem	Diagnostic Tips
The scanner is on but can not read bar codes. The LED is red.	<ul style="list-style-type: none"> ◆ The scanner window is dirty. Clean the scanner window as described in the Maintenance section. ◆ The presented bar-code type is not enabled. Select the bar-code type with the Configuration Guide. ◆ The scanner is disabled by the host. Refer to Section 1.5. ◆ The bar-code type you presented to the scanner is not supported by ALPHA-30.
The scanner is on, but the motor is not rotating. A bar code cannot be read. The LED is intermittently flashing red.	<ul style="list-style-type: none"> ◆ The scanner has entered into the sleep mode. Press the switch on the top or front of the scanner to wake up the scanner (or use the wake protocol. Refer to section 1.5)
The LED is alternating red/green and beeps are heard.	<ul style="list-style-type: none"> ◆ Possible failure of the scanning safeguard circuit. Disconnect the scanner from its power source immediately and contact your dealer.

Problem	Diagnostic Tips
The LED remains green.	<ul style="list-style-type: none"> ◆ The scanner is continuously seeing a bar-code. Remove all bar-code labels out of the scan volume of the scanner and try again. ◆ The scanner cannot send the data to the POS system. There is no proper handshaking between the scanner and the host. Make sure that all cables are connected and your POS system is ready to receive data.
The scanner does not accept more than two or three barcode labels.	<ul style="list-style-type: none"> ◆ There is no proper handshaking with the POS system. Switch on the POS system and check connection and communication settings.
The LED is orange.	<ul style="list-style-type: none"> ◆ The laser is not functioning. The laser is either defect or switched off by the temperature protection circuit. Turn off the scanner for 5 minutes and try again. Make sure the scanner has enough air ventilation and is not placed in direct sunlight.

Problem	Diagnostic Tips
A barcode is read by the scanner but not accepted by the POS system.	<ul style="list-style-type: none"><li data-bbox="577 172 1010 320">◆ The communication cable is not connected to the serial port of your POS system. Refer to the manual of your POS system to locate the serial port.<li data-bbox="577 344 1010 493">◆ The communication settings of the system and scanner do not match. Adjust the settings in order to be equal for both device.<li data-bbox="577 517 1010 665">◆ The communication cable does not suit your POS system.. Contact your dealer for the correct communication cable.<li data-bbox="577 689 1010 767">◆ The data format of the label is not supported by the software running on the POS system.